

**PACIFIC  
ENERGY**

# ////// SUPER 27HD

LEGENDARY PERFORMANCE  
FOR SERIOUS WOOD BURNERS

- ▶ **HEAVY DUTY 3/8" STEEL TOP**
- ▶ **ASH DISPOSAL SYSTEM STANDARD**
- ▶ **EPA2020 CERTIFIED, 1.8 GR/HR**
- ▶ **AIR INJECTED CATALYTIC-FREE  
RE-BURN SYSTEM**
- ▶ **15 YEAR FIREBOX WARRANTY**





**CATALYTIC-FREE TECHNOLOGY**

**MORE DURABLE**

**MORE RELIABLE**

**EASIER TO OPERATE**

## SUPER 27HD

For spaces up to 2000 sq. ft.

**Heat Output Cord Wood**  
**72,000 BTU**

38,200 BTU EPA Test Fuel

Efficiency (HHV)	71.3%
Emissions	1.8 gm/hr.
Log Size (recommended)	16"
Log Size (max)	18"
Firebox Size	2.1 cu.ft.
Viewing Area	122 sq.in.

**EPA2020  
CERTIFIED**

**2**  
GRAMS  
PER  
HOUR  
OR LESS

The Super 27 HD comes with these industry leading features:

- Heavy-duty collar and 3/8" steel stove top
- Easy-to-use ash disposal system
- Pedestal base and black door
- Upgraded 5/15 year warranty
- EPA2020 Certified
- Reliable, durable catalytic-free technology
- High capacity baffle system
- Multi-port combustion air injection system
- Air wash system for super clean ceramic glass
- Inside and outside combustion air capable
- Floating firebox for extended stove life
- Single-Lever Air Control
- Mobile Home Approved
- Extended Burn Technology (EBT)
- 304 Stainless Steel Baffle, Rails and Flame Shield
- North-South loading

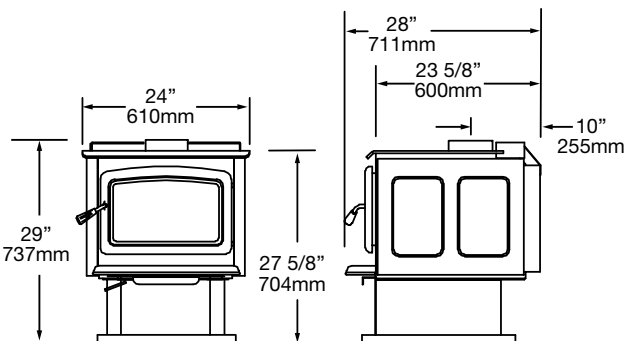

SKU 11900079

09/23/2.5M

Printed in Canada



[pacificenergy.net](http://pacificenergy.net)